

---

# DEVELOPMENT OF ULTRASONOGRAPHY FOR DOWNHOLE WELL INSPECTION

## PENGEMBANGAN TEKNOLOGI ULTRASONOGRAFI UNTUK APLIKASI BIDANG MIGAS

**Gathuk Widiyanto**

“LEMIGAS” R&D Centre for Oil and Gas Technology

Jl. Ciledug Raya, Kav. 109, Cipulir, Kebayoran Lama, P.O. Box 1089/JKT, Jakarta Selatan 12230 INDONESIA

Tromol Pos: 6022/KBYB-Jakarta 12120, Telephone: 62-21-7394422, Facsimile: 62-21-7246150

E-mail: gathuk@lemigas.esdm.go.id

First Registered on July 7<sup>th</sup> 2014; Received after Corection on August 8<sup>th</sup> 2014

Publication Approval on: August 29<sup>th</sup> 2014

### ABSTRAK

Salah satu upaya untuk peningkatan produksi dari *suspended well* dan sumur-sumur di lapangan marginal dan brownfield adalah dengan mengatasi masalah-masalah sumuran khususnya masalah mekanis. Salah satu parameter keberhasilan dalam mengatasi masalah mekanis sumuran adalah dengan melakukan identifikasi masalah secara tepat dan cermat. Untuk itu perlu upaya mengetahui integritas sumur, termasuk diantaranya adalah masalah mekanis sumur yaitu dengan menggunakan *downhole camera* (*downhole tools measurement*) untuk mendeskripsikan kondisi dalam lubang sumur. Pengetahuan tentang citra atau gambar kondisi lubang sumur untuk mengetahui masalah mekanis sumur, keperluan optimasi sumur serta penguasaan teknologi pencitraan sumur migas maka perlu pengembangan *downhole inspection* berbasis teknologi yang sudah terbukti. Teknologi *Ultrasonography* adalah teknologi yang sudah dikenal dan terbukti di dunia kedokteran untuk mencitrakan gambar /image didalam tubuh manusia dan benda-benda yang bergerak didalam tubuh dengan persentasi kesalahan yang sangat kecil. Saat ini telah berhasil didesain alat inspeksi sumur tahap III yang terdiri atas sistem elektronika, sistem mekanika dan sistem komputer serta sudah dilakukan uji kehandalan operasinya secara laboratorium. Sistem akuisisi yang sebelumnya dengan sistem “*real time*” diubah menjadi ke sistem memory karena sampai saat ini untuk *prototype* ini masih menggunakan motor stepper, sehingga apabila menggunakan system real time akan terjadi masalah pada waktu operasi di lapangan. Beberapa keunggulan dibanding alat serupa adalah kemampuan akuisisi sesuai dengan keinginan pengguna dan lebih mudah serta murah operasinya.

**Kata Kunci:** *suspended well, well integrity, ultrasonografi, inspeksi downhole*

### ABSTRACT

*One technique to increase oil production rate in marginal and suspended wells is solving mechanical problem. Success parameter to solve the mechanical problem is to identify this problem properly and accurately. One of the tools to identify the well integrity including mechanical problem in oil and gas industry is downhole camera used to describe bore hole conditions. Image is very important and is used as main parameter to determine the production and operation strategy. So, imaging technology transfer is very important especially on proven technology. Ultrasonography is proven technology in medical discipline to create image within human body without significant error. This research tries to apply ultrasonography technology in oil and gas industry. Recently, design and prototype of downhole inspection tools stage III have been completed. Prototype consists of electronic system, mechanical system and information system included acquisition system. Laboratory test of these tools has been conducted successfully. Acquisition system uses memory system within dry battery to avoid operation problem at field test. Several advantages of this tools are the small number data as per user's required, user friendly and simple in operation.*

**Keywords:** *suspended well, well integrity, ultrasonography, downhole inspection*

## I. INTRODUCTION

A well integrity is a hole well condition which guarantess that the deep well is in condition operated properly. In oil and gas production, the well integrity plays an important role because if the well integrity is not known exactly, it can cause a decrease or loss of production or the risk of work accident. In the frame work of increasing well production. One of the crucials that must be known is the hole well condition. In order to know, the hole well condition, the hole condition test is needed by using a special equipment. One of the efforts to know the mechanism condition of hole well is by using downhole tools measurement for desribing the condition of hole well.

The capability of in age ultrasonography, it is necessary to design a well inspection tool by using a nationl technology (SDM and Design) which has a high efficient that is cheap but has a double benefit.

By mastering the ultrasonography technology, it is expected that it will solve the problem of depleting national oil and gas production and provide the benefit for the government to increase national oil production and the development of human resource in the field of oil and gas. It needs technological breakthrough to solve oil and gas industry problems, in addition to quality products development which have a national competency basis.

One of the technological breaktroughs is well inspection technology development in oil and gas industry which has the ultrasonography technology basis been proved and tested in the medical world it becomes a design test equipment that is applied in oil and gas industry. This activity will have a great benefit and effects to national oil and gas industry particularly Human Resource Development and further technology development.

## II. METHODOLOGY

### A. Review of the Literature and Theoretical Foundation

The ultrasonic wave was first used during the second world war as sets of Sound Radiation and Ranging (SONAR) a part of submarine navigation. In 1929 and 1935 Sokolov introduced a method to evaluate steel with the ultrasonic, and in 1931 Mulhauser succeeded to patent flow detection method

in solid material with ultrasonic technique. In 1940 Fureston and Simon 1955 revealed the ultrasonic pulse technique which is used to test materials. At present it is being developed tomography system using ultrasonic wave for variety of materials. This method is relatively cheap and a it has no effect from radiation (Leighton, 2007).

Previous researches have been done to know a few important physical variables from the ultrasonic wave. In 2003 it has been done the ultrasonic pulse generator design with MCS-51 microcontroller basis. The research resulted a frequency and the amount of effective pulse to obtain maximum reflection pulse. Then in 2003 it also has been done research about ultrasonic pulse application to measure wave velocity on air and its implementation in measuring distance with reflection method. In this research it is obtained spatial resolution, distance measurement which has the most optimal 1 mm. The measurement Time of Flight, the ultrasonic wave has been developed and tested in gas medium and its implementation to measure gas temperature and it also can distinguish variety of passed gas based on Time of Flight wave (Suryono, 2007).

The advance of technology has resulted ultrasonogram namely; the imagery sets based on the concept of ultrasonic wave pulse reflection. In general the image with is resulted in the ultrasonogram instrument has five (5) modes i.e; amplitudo scanning model (A-scan) the output in the form of graphs, brightness scanning (B-scan) in the form of 2 dimension (2D) picture, magnitude scanning mode in the form of combination from A-scan and B-scan, 3 dimension modes (3D) and 4 dimension modes (4D) which can detect the movement (Spitzer et al, 2003). The fourth mode cannot visualize cross image and the value of image is not accurate, if it is used to analyse fisis enlargement because it occurs wave interference at the time of imaging (Pintavirooj et al, 2004) the example from B-Scan mode image shown in Figure 1.

The study of using ultrasonic wave for detecting the existance of cancer has been done with the Endoscopic Ultrasonography (EUS) method namely; the method is done by inserting probe to organ and resulted 2D image from detected cancer. The result of image can only explain the existance of cancer or not and it cannot explain in detail an anatomie pathology conditions (Laundanski et al, 2001).

The use of ultrasonic wave for testing solid materials has superiority in attainment farther with other wave methods. The test method of roughness surface profile with ultrasonic frequency 0.5 MHz, it can be used to determine the span of roughness 29 mm to 445 mm (Sukmana & Ihara, 2006).

The ultrasonic wave has also been used for image roughness surface with Continuous-Wave Ultrasound Reflectometry (CWUR) has also succeeded to do transducer which has centre frequency 3 MHz. The ultrasonic wave reflection from the method can image surface irregularity (Mitri et al, 2009).

Tomography image provides clearer result from other image methods because this illusion is done from variety of angles and reconstructed to become complete imagery information using algorithm and computer programs. In conventional image methods, a three-dimensional object, if it is done imagery with 2 dimension modes, so the information from reflected wave or is passed from 2 objects that are not homogen will cause the occurrence wave superposition so that object image cannot be obtained in detail.

Tomography has been used extensively in developing science and technology as one of the methods to know the structure of internal object. The technique can be used to map the distribution fisis quantity from the object without damaging and one of the alternatives to inspect the material (Yulianti et al, 2003). The tomographic technique has also been developed as an alternative image better by utilizing radiation to obtain reflection value distribution, attenuation, detail position, and detail dimension (Germaneau et al, 2008).

The first idea from tomography system appeared, When Radon (1896) presented a mathematical formulation about the function 2 dimension integral line reconstruction which is known as the Radon Transformation. The idea is then used by Bracewell (1956) to reconstruct micro wave from the surface of the sun. Then Cormack (1963) used the function to reconstruct image from gamma ray radiation in aluminum tube. Hounsfield (1967) is the first one that succeeded to implement. Radon function for modern tomography image uses a computer (Radon, 1983).

At present the tomography technique has been developed for variety of purposes. Tomography method has been successfully used to inspect the

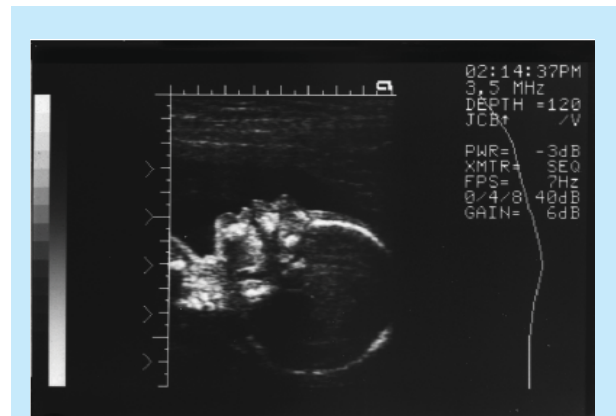

**Figure 1**  
**Mode brightness scanning**  
**(B-scan) ultrasonogram image (Szabo, 2004)**

differences of yellowish metal quality using isotope I-131. The research resulted the conclusion that the quality of the of yellowish metal can be analysed from image contrast linier attenuation coeficient value to source of used radiation (Suparta & Handayani, 2009).

Tomography using two sources of gamma radiation has also been developed by putting the radiation source Tc-99m outside and inside the object. The method combines two tomographic mapping models by means of transmission and emission. The results of both methods are combined and obtained images that can be used to interpret the physical condition of the fisis internal object under test (Suastika et al, 2009).

The tomography system using ultrasonic has been tested on variety problems. The ultrasonic tomography systems for medical diagnostics has been successfully used to detect cancer, cysts, pathology, anatomy organ, also detect the thick cortex and the long fetus bone in the womb (Laudanski et al, 2001; Lasaygues, 2006).

In NDT (Non-Destructive Test) application, the ultrasonic tomography has been used for the-like image (Deidda and Ranieri, 2006) and related investigation connected to exploration drill and also to see the structure of soil layer. The tomography system uses velocity mapping method with transducer contact which has 500 KHz frequency. The image method resulted the image with 52x52 pixel and spatial resolution 1.8 mm (Martin et al, 2007).

The application of ultrasonic tomography system in instrumentation and control has also been

implemented for monitoring on-line, non-invasive and non-intrusive. In this research, attenuation method is used with transducer contact that has 2 MHz frequency. This method can image and distinguish between gas bubble and water. The resulted image has spatial resolution 1.2 mm. The system cannot penetrate tested solid material. (Warsito et al, 1999; Supardan et al, 2007).

The ultrasonic tomography system has also been used to detect a type of gas and bubble which can be done filtration without interruption so that it can increase productivity, uniformity, and minimize input materials, reduce energy consumption, lower environmental damage and reduce a bad effect to the nearest people. The ultrasonic tomography is developed to investigate gas mixture flowing to the pipe with velocity mapping method using multitransducer at 40 KHz frequency configured in the form of fan-bean. Transducer model which is used is the type of transducer contact with high tension of 20 Vpp pulse. The image System can result in gas flow image 10 picture/second. The resulted image cannot penetrate solid materials and cannot explain the type of gas investigated (Rahim et al, 2007). By using similar tools, the tomography system is used to image gas-mixture, but it cannot explain the type of gas investigated (Rahiman et al, 2008).

**Theoretical Foundation**

**The Ultrasonic Wave**

The ultrasonic wave is a wave with frequency above the sound frequency, namely more than 20 KHz. As it was mentioned that the ultrasonic sensor consists of ultrasonic receiver chains called receiver. The ultrasonic signal which is generated will radiate from the ultrasonic transmitter. When the signal hits stumbling back, the signal is reflected, and received by the ultrasonic receiver. The signal which is received by receiver chains is sent to microcontroller chains and then is processed to count the distance in front of it (reflected field).

The principle work of ultrasonic sensor can be shown in the below picture:

The principle work of the ultrasonic sensor are as follows:

1. The signal is transmitted by ultrasonic transmitter chains. The frequency signal is above 20 kHz.
2. The Signal which is transmitted will creep as signal/sound wave with sound velocity is about

340 m/s. The signal will then be reflected and will be received back by the ultrasonic receiver.

3. As soon as the signal rescher the ultrasonic receiver, then the signal will be processed to count the distance. The distance is calculated by the formula:

$$S = c.t/2$$

where S is the distance between Ultrasonic sensor with the reflected field, c is wave velocity in the medium (air, water or solid) and t is time difference between the ultrasonic wave radiation to be received back by part of ultrasonic receiver.

**B. Engineering Method**

The implementation method of prototype engineering of oil and gas inspection wells for the third year can be seen in Figure 3.

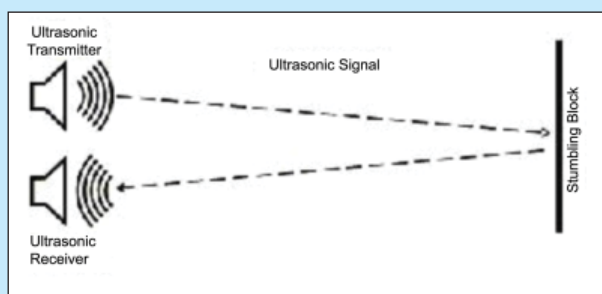

**Figure 2**  
The principle work of ultrasonic sensor

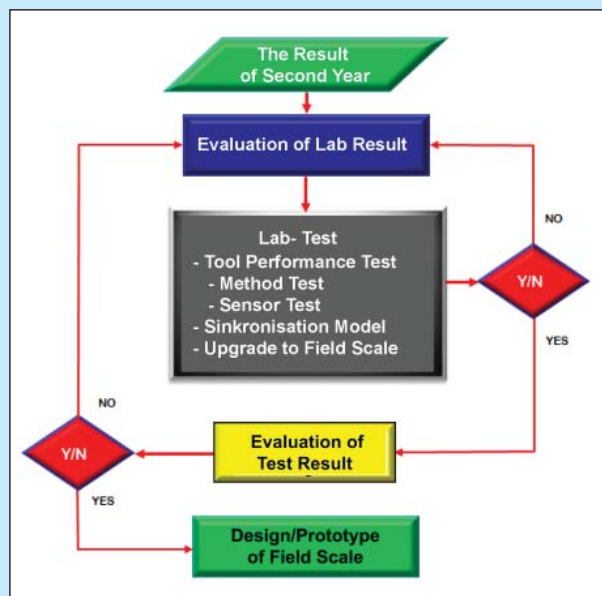

**Figure 3**  
The implementation method of engineering



## Equipment and Materials

In engineering of well inspection tools based on the ultrasonography technology, materials and equipments are needed as follows:

- The metal sheet for casing from non-corrosion steel materials
- The metal sheet for centralizer from non-corrosion steel.
- The ultrasonic transducer diameter 20 mm/ diameter, 2 MHz frequency, the transmitter-receiver, can stand on solid, liquid and air Media.
- The motor Stepper, Full step 0.5 Ampere, 2 phase.
- Multiplexer signal chains 6 to 1 High Voltage.
- Microcontroller RS232, tension level RS232, 32 single line mode.
- The pulse Generator with the basis of Microcontroller RS232.
- The board Signal Processor, 8 bit resolution, 16 Mhz.
- Logger Data.
- Battery
- Oscilloscope
- Digital Multimeter
- Computer
- Tools and supporting materials such, glue, acrylic, etc.
- Use up tools & materials.

## Design picture

The Design picture is adapted to the size and tool chains dimension and the needs to be used in the field. (see attachment).

## The main Systems

The main operational system of wellimpection tools with the basis of the ultrasonography technology which covers electronic systems, mechanical systems, computer systems, and supporting systems.

## Electronic system

### The ultrasonic Transmitter

The ultrasonic transmitter is chain which transmitter pulse wave with 1 MHz frequency using a transducer of using a transducer of the ultrasonic transmitter.

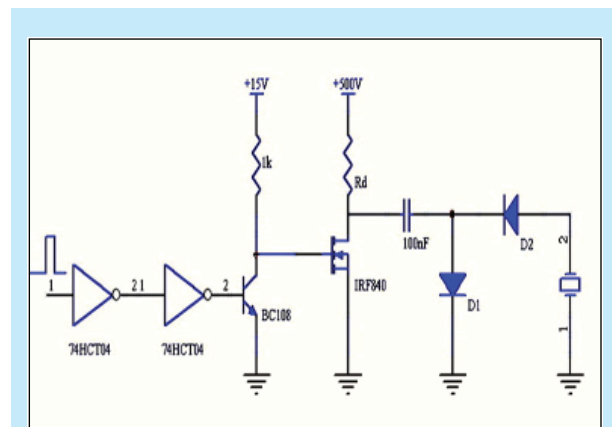

**Figure 4**  
**Ultrasonic wave transmitter chains**

The principles work of ultrasonic wave transmitter chains are as follows:

1. 1 MHz signal is generated through the microcontroller.
2. The Signal is passed on 3k Ohm resistor for safety when the signal to infracts to dioda to chains and transistors.
3. Then the signal is inserted to the current power chains which are the combination of 2 diodas and 2 transistors.
4. When the signal from the input has logic (+5V) so the current will pass dioda D1 (D1 on), then the current will refract T1 transsistor, the current which will flow to T1 collector will be big in accordance with the intensity of the transistor.
5. When the signal has high logic (0V) so the current will pass diode D2 (D2 on), then the current refract T2 transistor, the current which will flow to T2 collector will be big in accordance with the intensity of the transistor.
6. R4 and R6 resistors will function to share the tension to 2.5V. The ultrasonic Transmitter will receive alternating tension with Vpeak is 5V (+2.5 V to -2.5 V).

## The Ultrasonic Receiver

The ultrasonic receiver will receive ultrasonic signal which is transmitted by the ultrasonic receiver with the right frequency characteristics accordingly. The signal which is received will pass filterisation frequency process using bond passchains with frequency value has been decided.

### Mechanical System

The motor which is used for translation movement and rotation in this research. It used tension of DC (direct current) 12 V, the current 400 mA, it has 4 pole/2 phases-the motor has rotational resolution 1.8°/steps (without reducer). The regulator of motor movement is motor digital logic which has tension level 5 V and the current 10 mA. Therefore, it needs activator chains, it functions to increase micro controller tension level until it reaches, tension on the current on the motor. The motor chains is shown in Figure 5.

### Computer System

In engineering research of well inspection tool with the basis of the ultrasonography technology, the software which is used the general software and is easy to obtain in the market are as follows:

- a. Altium Designer Release
- b. AVR Studio 4.0
- c. Code Vision AVR C Compiler
- d. Boll and Delphi 7.0.

However, in this engineering, modifications is also done for its computer fractions, For controlling the number on this system, it is carried out through instruction of microcontroller program used Atmega 8535 microcontroller. The diagram of block system Time of Flight ultrasonic wave is shown in Figure 6.

### Supporting System

#### a. Aquisition system

In addition to record serial data from RS232 connected to logger data, the logger data also records

analog data through (Analog to Digital Converter) with the wide data 10 bits. ADC sampling is carried out once every 20 ms. So with the existance 8-channels, 10 bits ADC this, will make logger data DL1000A become more flexible in its application. Output from logger data is usually in the form of format file \*.txt which is compatible to the computer. This will case the use, because the file with format \*.txt can be read with are application program such as notepad or other text editors or microsoft excel.

#### b. Battery

The Nickel-Cadmium battery is a solid substance which attaches to two electrodes. The Nickel Cadmium cells resulted difference potential 1.4 Volt. By alternating electronic current, the substances can be changed back as initial substance the more benefined of the Nickel Cadmium battery are as follows:

- It can by recharge
- Practical, and portable
- The potential of its cell/the current which is produced remain constand during the use of it because reaction result an every its electrodes in the form of solid.
- It can be obtained in many kinds of size.
- The battery can remind the amount of energy release at the time before charging.

Reminder effect is caused by the change occurred on the structure of electrode crystal when nickel-cadmium battery is charged electric current, it will be back before all electrical energy in the nickel-cadmium battery is released/used

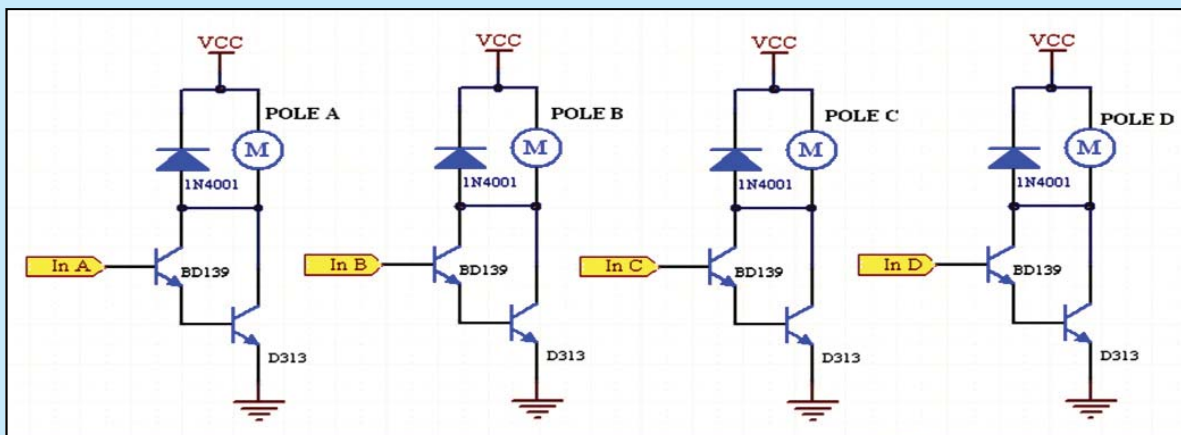

Figure 5  
Motor activator chains

### III. RESULTS AND DISCUSSIONS

#### A. The result of Electronic System Test

Result of making ultrasonic wave generator system

The test of ultrasonic pulse generation system covers, the stability test of excitation pulse, the test of power portion source high tension MOSFET DC, and the test of MOSFET output tension relation to variety drain obstacles. The test is carried out by using GE transducer inspection technologies Z1N type with the centre of frequency 1 MHz. The test is carried out using measurement tools, multimeter and Digital Storage Oscilloscope Textronic TDS-2100.

In this system, the pulse wave is generated through Pin A, 0 with SETB assembly command and to provide high logic to the pin. Then, the postponement is carried out for 1  $\mu$ s pulse to form pulse as wide as 1 MHz in accordance with its transducer frequency. Then, the pin is given assembly CBI command to obtain low logic and is postponed for 100  $\mu$ s to provide the distance of further pulse. The pulse which is produced by microcontroller is generated repeatedly so that it can be seen on the oscilloscope.

Figure 7 and 8 above show the form microcontroller excitation pulse on pulse width which is tested namely 1  $\mu$ s and 250 ns. From the result of the pulse test, it obtains of 99.89% stability value on the width 1  $\mu$ s and 99.07% on the pulse width 250 ns so that the pulse source is very good to be used for further needs.

#### B. The Results of Receiver Chains Test

The receiver chains on ultrasonic tomography system cover buffer chains, strengthener chains, and comparator chains. Before strengthener is carried out using receiver chains, first the receiver transducer signal measurement is done on the immerse medium in the form of water without sample. The result of this measurements is very important, because it will be used for reference tension on the receiver chains. The signals which is received by transducer chains through water immerse medium as long as 27.4 cm is (20.4  $\pm$  0.6) volt. If in the medium is given sample of concrete material test with the thick (8,06  $\pm$  0.02) cm, so it obtains the signal on tranducer receiver (487.4  $\pm$  16.9) mV. From this value, it can be concluded that on the sample immerse on the water resulted big atenuation.

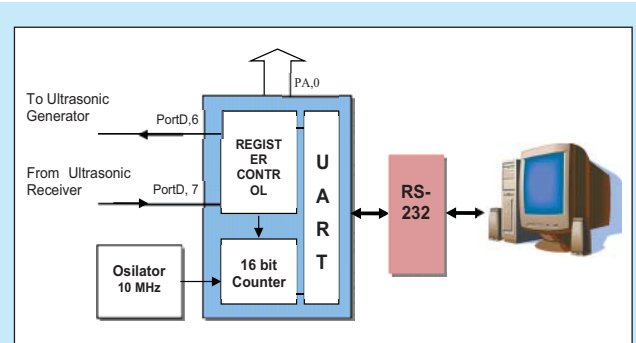

Figure 6  
The architecture of microcontroller for the measurement time of flight and interface UART serial computer

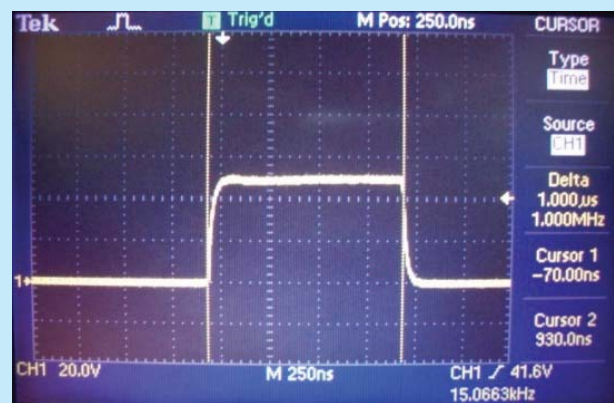

Figure 7  
The form of excitation pulse ultrasonic generation on pulse as wide as 1  $\mu$ s



Figure 8  
The form of excitation pulse ultrasonic generation on pulse as wide as 250 ns

Figure 9 shows the signal result from the receiver on the ultrasonic transducer in the water immerse medium.



### The result of Mechanical System Test

The test on rotational resolution to obtain projection angle ( $\Delta Y_{\phi}$ ) is done by counting the amount of power portion on the pole in one circle motor ( $360^{\circ}$ ). The first test is done to the movement of rotational motor before the reducer is given. The result of the use is made graphic relation between the the amount of steps to rotational angle which is resulted and obtained the result shown on Figure 10. From the graphic, it obtains rotational resolution of motor which is used is 1.8 (step)/stroke.

From the graph, it obtains the accuracy of rotational motor movement  $0.9^{\circ}$ /stroke and it has standard deviation  $SD = 0$ . From the value, it can be concluded that rotational movement electromagnetic system to obtain ( $Y \Delta_{\phi}$ ) value, it has very good characteristics and what it is expected.

### The Result of Computer System Test

The result of scanning ultrasonography sample is shown on Figure 4.10. The Figure shows the graph from the variety of projection angles on  $0^{\circ}$  and  $360^{\circ}$ . From the graph, it can be explained that the initial and final scanning show time and Flight value in accordance with the surface object. The results of software application is shown on Figure 11.

From the application, it produced recording result in the form of sting (text)data which can be



Figure 9  
The signal on tranducer with water medium

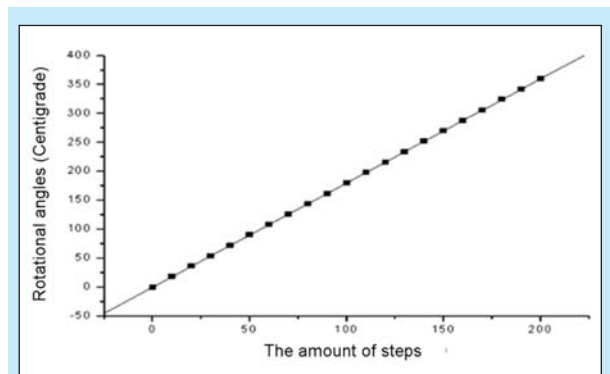

Figure 10  
The graphic, the result of characteristics of rotational angle of motor step

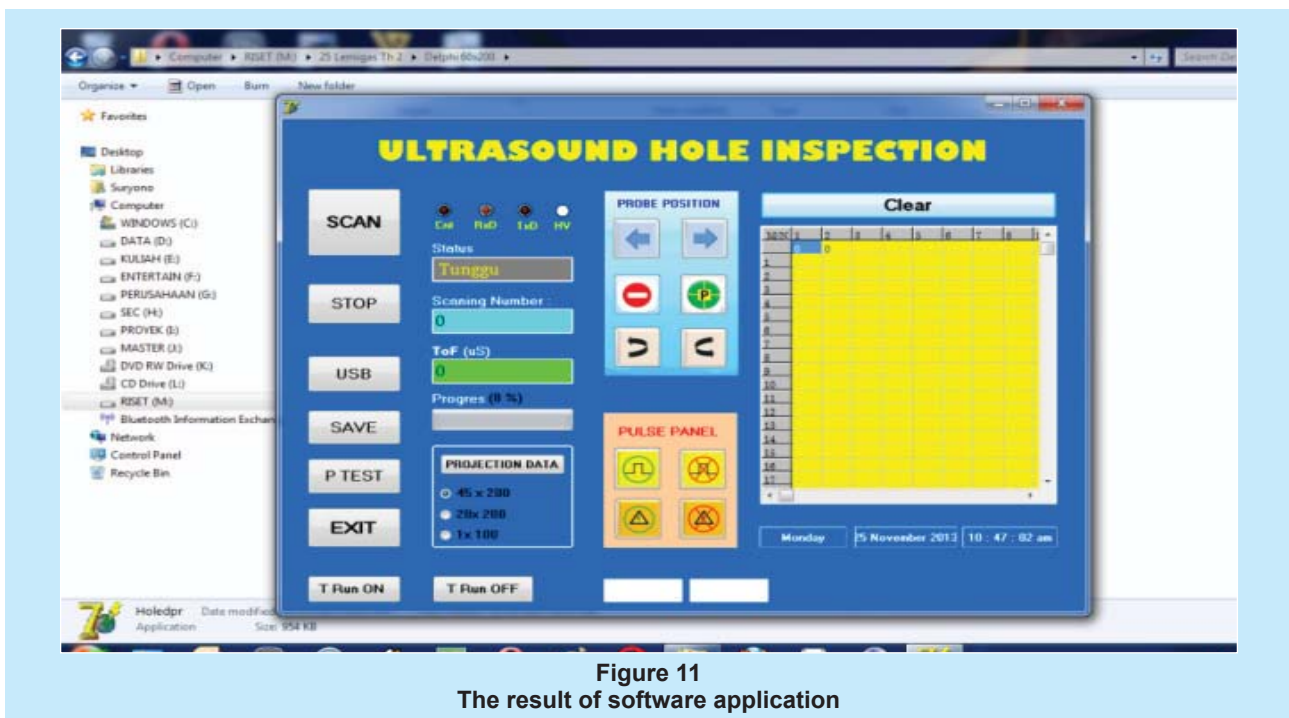

Figure 11  
The result of software application



kept and opened using notepad application as shown in Figure 12.

Acquisition system is designed using memory system or logger data or batch. Where the system has the following superiority:

### 1. Time Lag

In the batch system, variety of data from transaction is first classified in a processing batch before the data is inserted to the system to be processed. The effect is obvious, there are time logs between the point/during transaction with the point/at time of noting transaction into the record. The length of the time will depend on the frequency of batch processing, in the minute, daily, weekly, total of batch pile. Whereas in the real time system, time lag is omitted. Data is processed during transactions, so that the record will automatically up date or in other words the data is always up to date.

### 2. The Power Sources

On batch systems, the needs of power source are relatively small compared with the real time system. For example; during system development, a program activity is relatively simple and it needs shorter time compared program activity on the real time system. On the real time system, the application program is usually complicated, such as the demand of interface which is designed must be easy to be used by user friendly, using pop-up menu, direction facilities on-line, help, etc. From the infrastructure side, the real time system needs computer with high capacity processing and is dedicated. It meant that because the real time system related directly with transaction, when transaction appeared, the system must be usually available 24 hours/day it is used or not. So the company needs funds which are expensive to be invested into the system, buying computer which has the capability required. Whereas, the batch system can only be used when the program is run so the computer must not have high capacity such as on the real time system.

### 3. Efficiency and Effectiveness

If it is seen from data processing efficiency, so the, batch system is more superior. The batch system, once, the data is processed in the big amount so the cost per unit is low. Whereas concerning the effectiveness, if the need of information is soon the data is processed quickly, the information must be available any time when it is needed, so the accurate

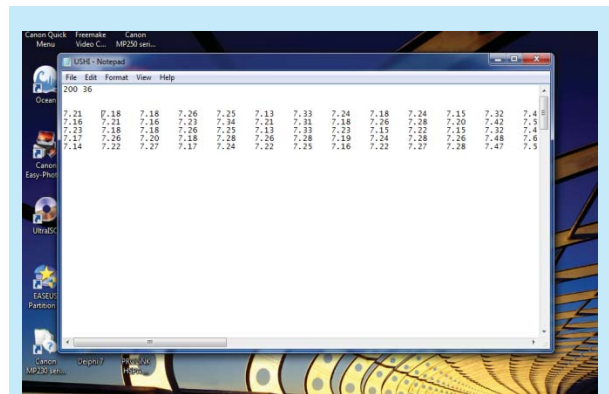

Figure 12  
The result of acquisition data notepad Application

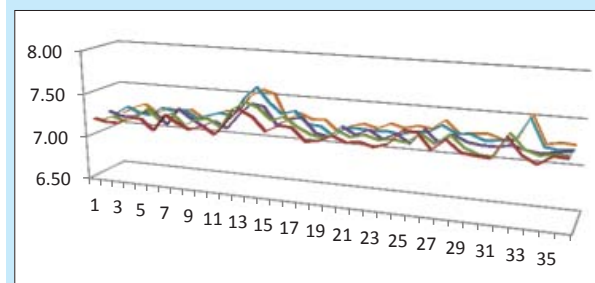

Figure 13  
Graph of data processing result

system is the real time. So, we must consider the characteristics data processing model with the needs of user in designing the system. For example, ceasing time does not interfere badly/the lost of user performance, it is economical in batch processing in the big amount, so the system which is precise is the batch system.

### The Results of the Whole System Test

The test is done by doing sensor test and stepper motor and supporting system wholly. The test result can be seen in the below Table.

From the data processing, it can be processed in the form of graphic. For example in Figure 13 is the graph acquisition results which is processed in Microsoft excel

### B. Discussions

The downhole inspection is designed with the capability which can function as downhole camera, but using ultrasonography technology with certain superiority compared with similar tools with other technology such as, XY Caliper and Infrared. XY Caliper is indeed a tool for a well inspection with

the newest generation the amount of Arm 42, its limitations is the tool can only take data horizontally in 42 points in accordance with the amount of existing arm, whereas the tool which is designed, the data taken in accordance with the needs of the user are unlimited. The operational cost of xy caliper is also more expensive compared with well inspection tool with a basis of ultrasonography, because it can be run only with wire on slickline single drum or when there is a rig with sand line.

Downhole camera with infra red technology has limitation on the well with thick mud liquid or heavy crude oil will influence the result of its image, beside it is also expensive in its operation because it must use multi conductor cable. It is seldom and expensive in Indonesia.

Based on the graph on Figure 13 it can be seen from the results of image. Well inspection tool with a basis ultrasonography, where the data can be developed for biosa shown in three dimensions. In addition, this tool can still also be developed with the other additional function with ultrasonography technology for instance, for Cement Bod Log or stimulation tool certainly with variation and a specific sensor.

#### IV. CONCLUSIONS

1. The tool which has been developed has been able to identify wall with unflat surface with the accuracy of 1 millimetre.
2. All systems has functioned well namely; electronic system, mechanical systems, and computer system has been proved at the time the whole system test where it can identify wall and circle in accordance with the needs.
3. In laboratory scale, acquisition system uses the real time system whereas in the field scale, data logger system is used to anticipate the obstacle of technic of fields.
4. The well inspection tool works by circulating 360° centigrade with the step which can be arranged in accordance with the data needed.
5. The tool will be cheaper (a part of local content) it is suitable for small and middle operator (national private).

#### ACKNOWLEDGEMENT

We would like to express out gratitude and appreciation to the late Prof (R). Dr. Suprayitno

Munadi, M.Sc. who has given inspiration in implementing this engineering research. Our gratitude is also given Dr. Suprajitno Munadi, M.Sc. who has supported his thought and assistance in this research activity.

#### REFERENCES

- Prof. (R). Dr. Suprayitno Munadi, Drs. Bambang Triharjanto**, 2005, Mengenal Full Waveform Sonic Log dan Borehole Televiewer, Pusat Penelitian dan Pengembangan Teknologi Mineral dan Batubara, Bandung.
- Rahim, R.A., Rahiman, H.M.F., Chana, K.S., & Nawawi, S.W.**, 2007, Non-invasive Imaging of Liquid/gas Flow Using Ultrasonic Transmission-mode Tomography, Sensors and Actuators Journal A: Physical, Volume 135, Issue 2, 15 April 2007, Pages 337-345.
- Rahiman, H.M., Rahim, A.R., & Zakaria Z.**, 2008, Design and Modeling of Ultrasonic Tomography for Two-component High-acoustic Impedance Mixture, Sensor and Actuator A : Physical Volume 147 p. 409-414.
- Rose, L.J.**, 1999, Ultrasonic Wave in Solid Media, Cambridge University Press, Boston.
- Sukmana, D.D., & Ihara, I.**, 2006, Novel Noncontact Method for Characterizing Surface Profile by Air-Coupled Ultrasound Scattering, Advances in Technology of Materials and Materials Processing Journal, Volume 8 pages 248-255.
- Supardan, D.M., Masuda, Y., Maezawa, A., & Uchida, S.**, 2007, "The Investigation of Gas Holdup Distribution in a Two-phase Bubble Column Using Ultrasonic Computed Tomography", Chemical Engineering Journal, Volume 130 pages 125-133.
- Suprijanto**, 2008, Penguasaan Teknologi "Medical Imaging". IATF-ITB.
- Suryono**, 2007, Identifikasi Sederhana Beberapa Jenis Gas Menggunakan Gelombang Pulsa Ultrasonik, Proseding Seminar Nasional Kimia 2007 FMIPA UNDIP Semarang.
- Suryono, dan Djamal, M.**, 2003a, "Design of Ultrasonic Pulse-wave Generator Base in Microcontroller AT89C2051", Proceeding of Annual Physics Symposium, ITB Bandung.
- Suryono, dan Djamal, M.**, 2003b, "Perancangan Peralatan Ultrasonic Ranging Berbasis Mikrokontroler AT89C2051", Proseding Seminar Nasional, Instrumentasi Berbasis Fisika Basic Science.
- Suryono, dan Djamal, M.**, 2003c, "Pencacahan Time-of-Flight Gelombang Ultrasonik Pada Medium

Gas Menggunakan Mikrokontroler AT89C2051”,  
Prosiding Seminar Nasional Instrumentasi dan  
Kontrol 2003, Teknik Fisika ITB Bandung.

**Suryono, dan Djamal, M.**, 2005, “Sistem Pengukuran  
Temperatur Ruangan Menggunakan Gelombang  
Ultrasonik”, Berkala Fisika Volume 7 No. 1.

**Suryono, Kusmarto, GB Suparta.**, 2010, Rancang  
Bangun Pembangkit Pulsa Ultrasonic untuk Material  
Padat Berbasis Microcontroller., Prosiding Pertemuan  
Ilmiah XXIV HFI hal 247 - 251, Semarang, 10 April.

**Suryono, Kusminarto, Suparta G.B.**, 2010, Estimation

of Solid Material Surface Roughness Using Time-  
of-Flight Ultrasound Immerse Transducer, Journal  
of Materials Science and Engineering, USA, vol. 4  
No.8, pp. 36-29

**Suryono, Kusminarto, Suparta G.B.**, 2011, Ultrasonic  
Computed Tomography System for

**Syafrudin Agus, Suryono, E.Suseno Jatmiko**, 2008,  
Rancang Bangun Generator Pulsa Gelombang  
Ultrasonik dan Implementasinya untuk Pengukuran  
Jarak Antar Dua Objek, Berkala Fisika, ISSN 1410 –  
9662, UNDIP, Semarang.